

Stage 1 Area 3

11 rounds

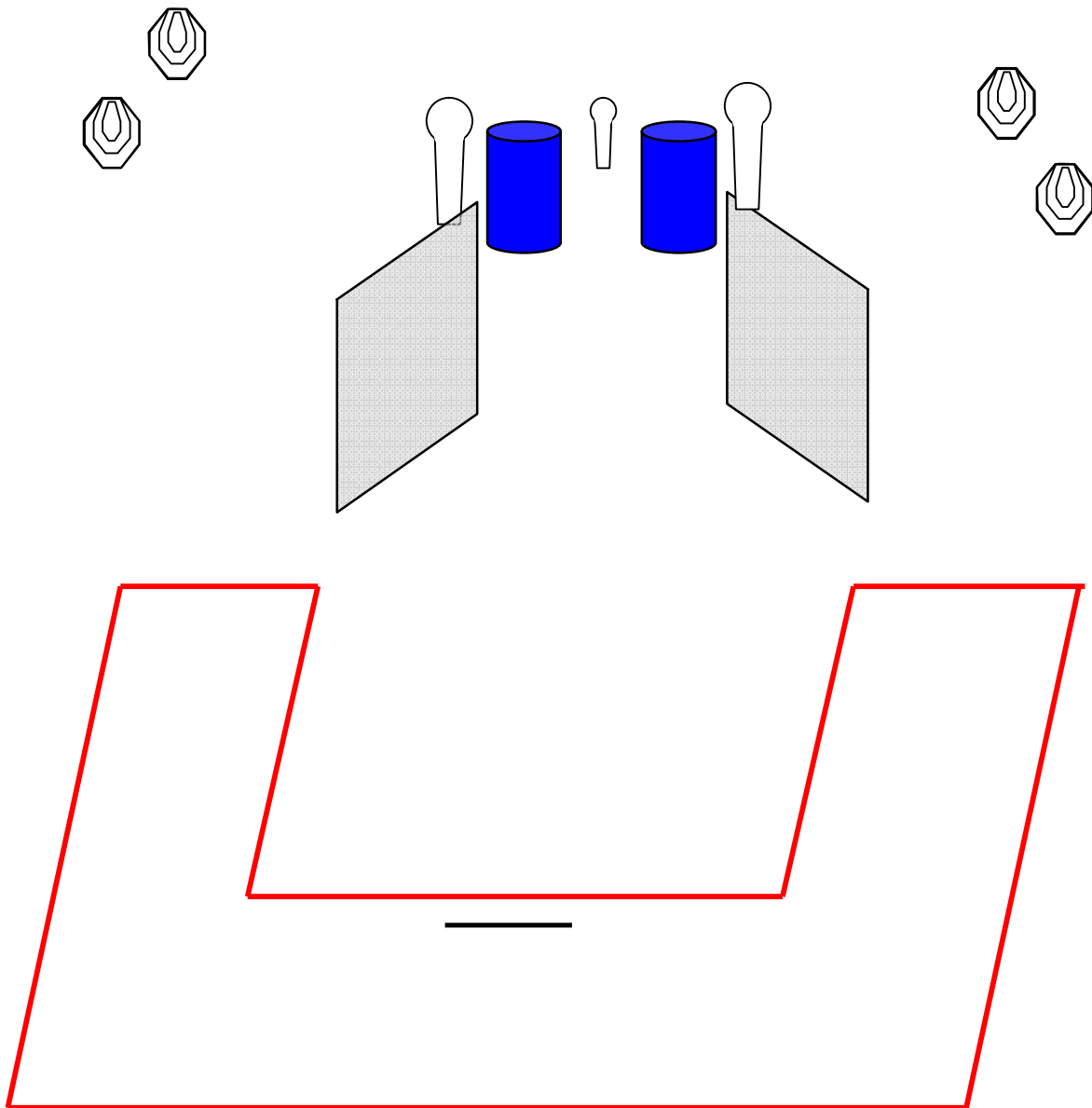

Targets	4 IPSC Targets, 2 IPSC Poppers, 1 mini Popper
Rounds to be scored	11
Start position	Standing , top of the boots touching the black line.
Time starts	Audible signal
Procedure	At the start signal engage targets from within the designated area.

Stage 2 Area 4

24 rounds

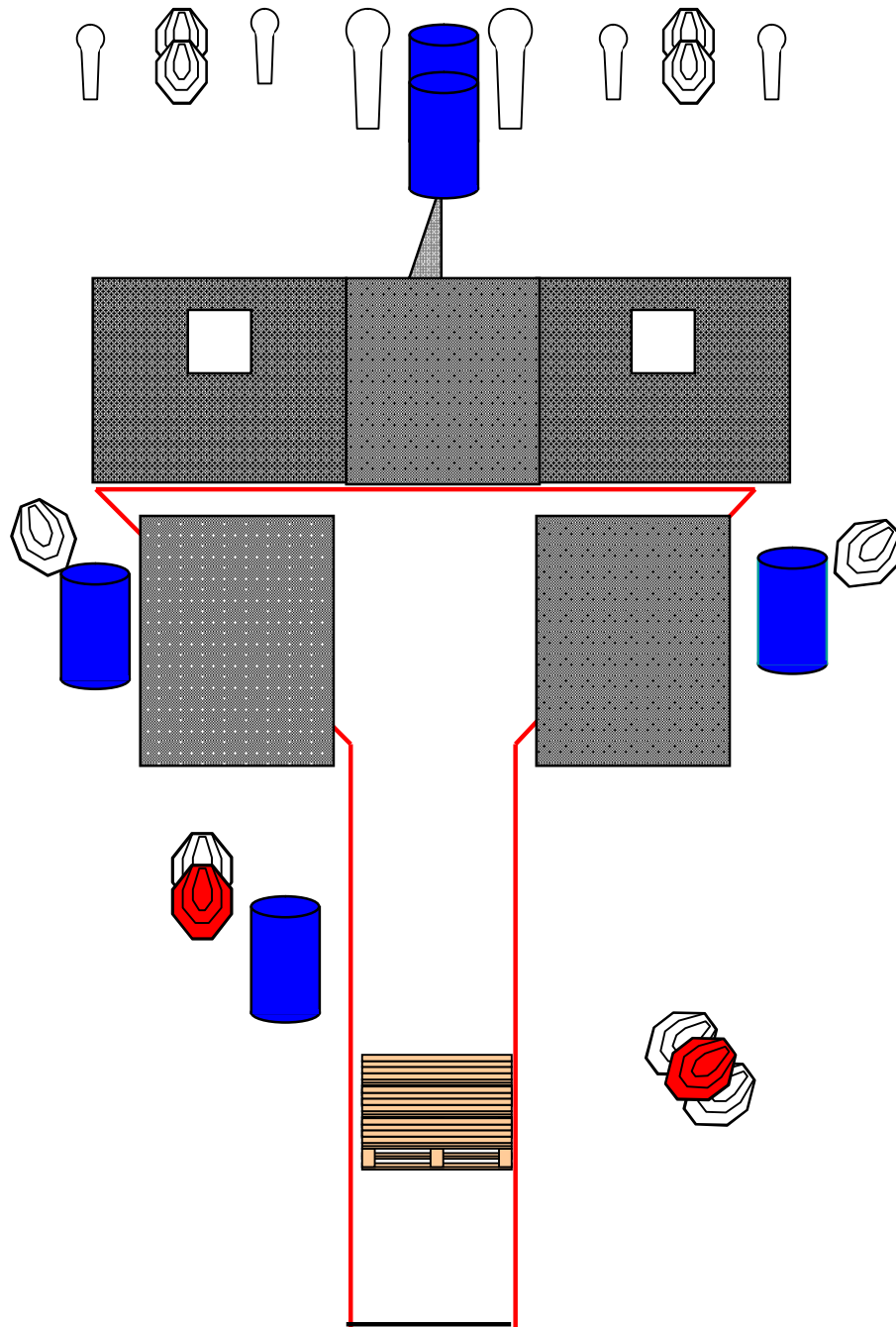

Targets	9 IPSC Targets, 2 IPSC Poppers, 4 IPSC Mini Poppers
Rounds to be scored	24
Start position	Hills touching the black line
Time starts	Audible signal
Procedure	At the start signal engage targets from within the designated area.

Stage 3 Area8

12 rounds

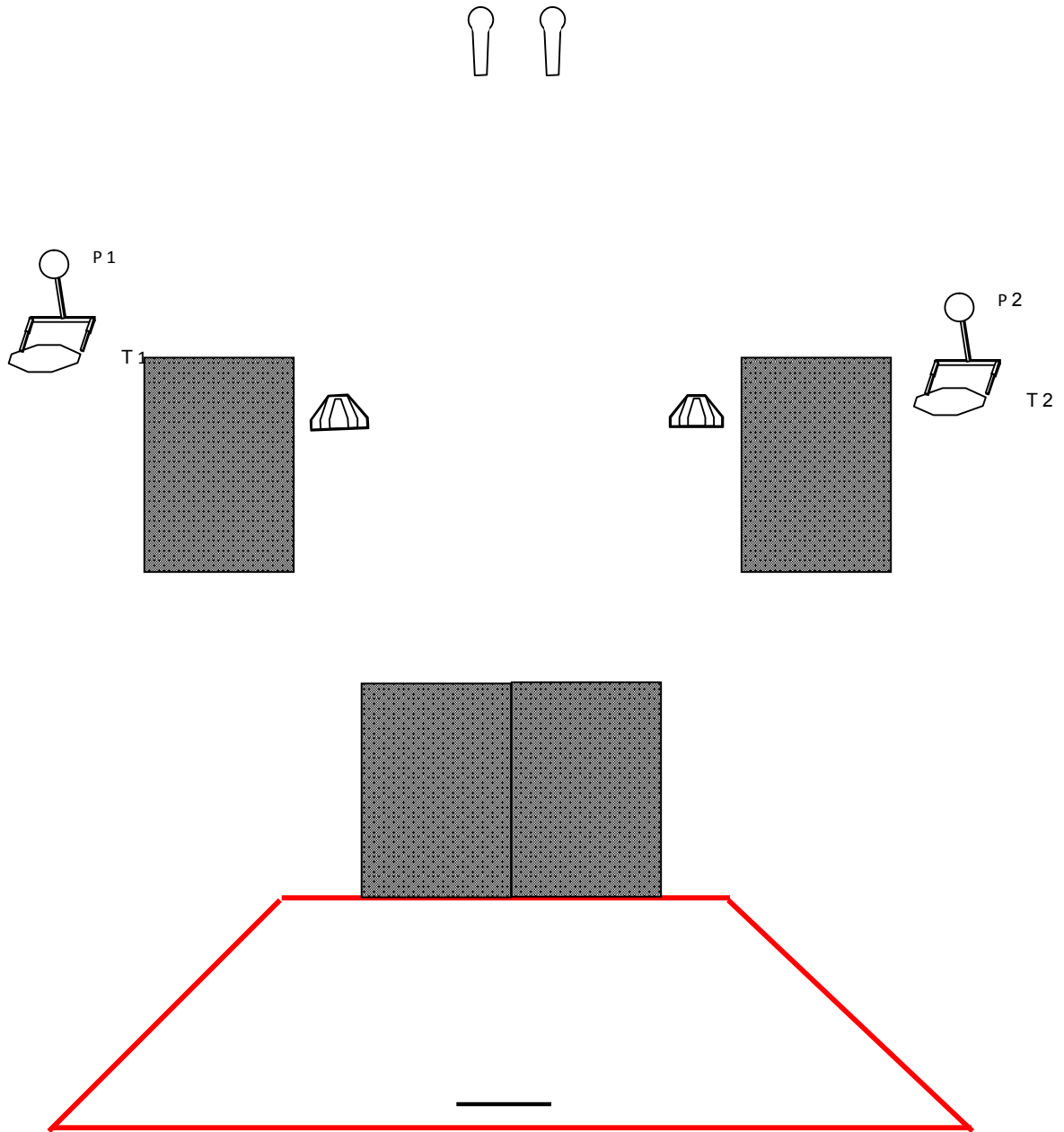

Targets	4 IPSC Targets, 2 IPSC mini Poppers, 2 Plates
Rounds to be scored	12
Start position	Standing , heels touching the black line.
Time starts	Audible signal
Procedure	At the start signal engage targets from within the designated area. P1 & P2 activate T1 & T2

Stage 4 Area9

29 rounds

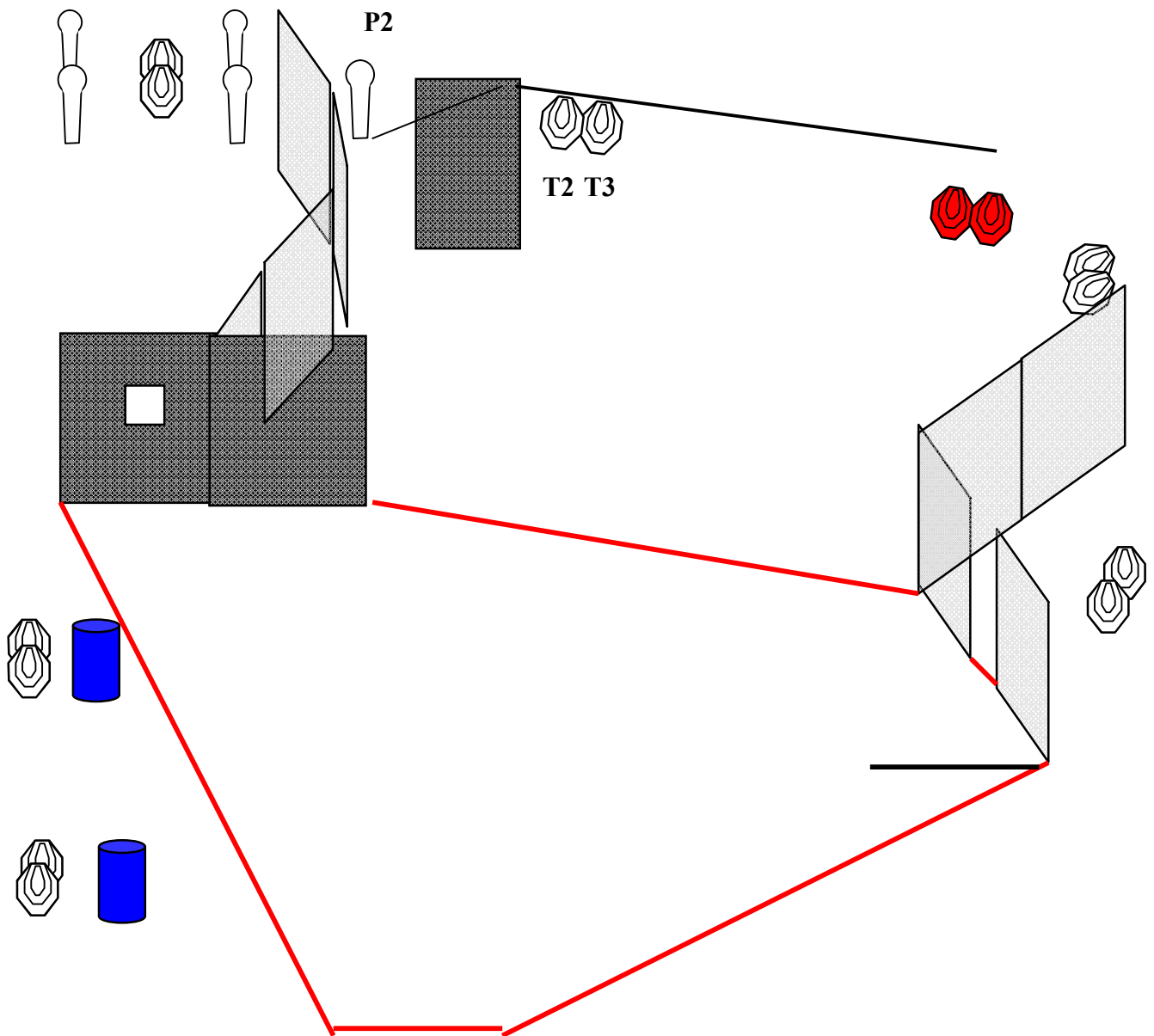

Targets	12 IPSC Targets, 3 IPSC Poppers, 2mini Poppers
Rounds to be scored	29
Start position	Standing , heels touching the black line.
Time starts	Audible signal
Procedure	At the start signal engage targets from within the designated area. P2 activates T2, T3. All moving targets remain visible at rest.

Stage 5 Area10

9 rounds

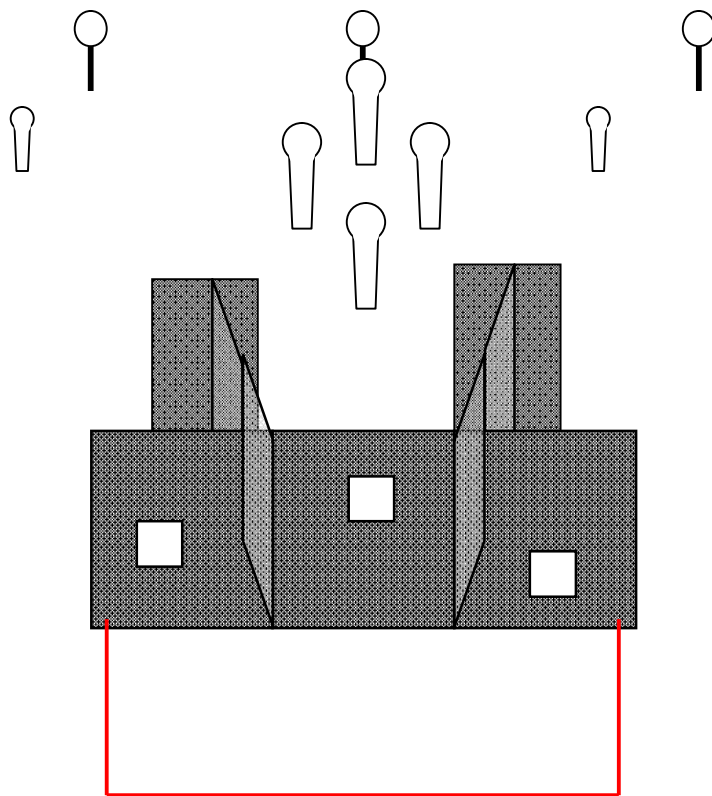

Targets	3 IPSC Metal plates, 4 IPSC Poppers, 2 mini Poppers
Rounds to be scored	9
Start position	Standing, anywhere in marked area
Gun state	Chamber empty
Time starts	Audible signal
Procedure	At the start signal engage targets from within the designated area.

Stage 5 Area12

20 rounds

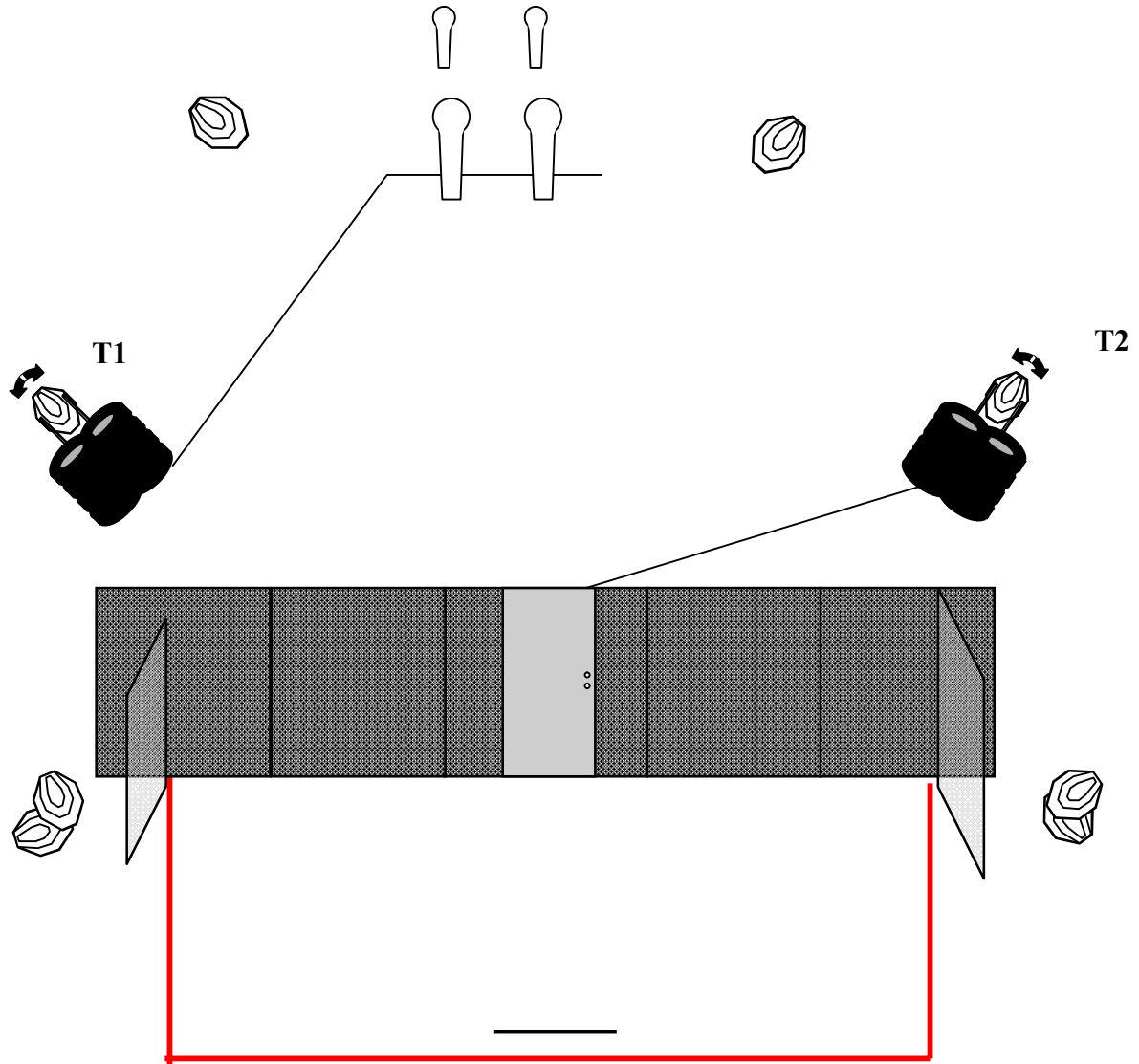

Targets	8 IPSC Targets, 2 IPSC Poppers, 2 mini Poppers
Rounds to be scored	20
Start position	Standing , heels touching the black line.
Time starts	Audible signal
Procedure	At the start signal engage targets from within the designated area. The door activate T1, T2, T3. All moving targets remain visible at rest.